

UNC

UNC



UNC

Filettatura americana UNC passo grosso ASME B1.1

UNC coarse thread ASME B1.1

Unified Grobgewinde UNC ASME B1.1 – Satz Handgewindebohrer

Filetage américain UNC ASME B1.1 – Jeux de tarauds à main

Rosca gruesa UNC ASME B1.1 – Juegos de machos de roscar a mano



N

USO GENERALE

General purpose - Usage Général

MASCHI A MANO

HAND TAPS - TARAUDS MAIN

DIN 352

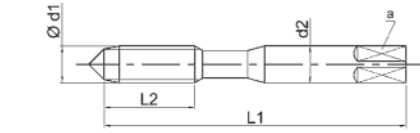

DIN 352

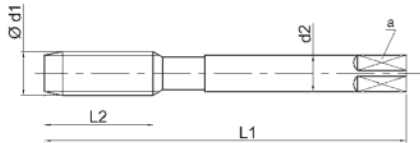

UNC



LINE



A 5-6

LINE



D 4-5

LINE



C 2-3

LINE



Profond. di filettatura - Thread depth - Profond. de filetage

2xD

2xD

2xD

2xD

Materiale - Material - Matériau

HSS

HSS

HSS

HSS

Tolleranza - Tolerance - Tolérance

-

-

2B

2B

Trattamento superficiale - Surface treatment - Revêtement

BR

BR

BR

BR

Numero gruppi materiali
Material's groups number
Nombre de groupes du matériau

1.1 1.2 1.3 1.4

1.1 1.2 1.3 1.4

1.1 1.2 1.3 1.4

1.1 1.2 1.3 1.4

2.1 2.2 2.3 3.1 3.4

2.1 2.2 2.3 3.1 3.4

2.1 2.2 2.3 3.1 3.4

2.1 2.2 2.3 3.1 3.4

4.1 4.2 4.3 4.4

4.1 4.2 4.3 4.4

4.1 4.2 4.3 4.4

4.1 4.2 4.3 4.4

5.1 5.2 5.3

5.1 5.2 5.3

5.1 5.2 5.3

5.1 5.2 5.3

DIN 352	Ød1 UNC	P TPI	Ø mm	L ₁	L ₂	d ₂ h ₉	a h ₁₂	Z	
6	32	3,505	45	10	4	3	3	2,85	◀
8	32	4,166	45	11	4,5	3,4	3	3,5	◀
10	24	4,826	50	13	6	4,9	3	3,9	◀
12	24	5,486	56	15	6	4,9	3	4,5	◀
1/4	20	6,350	56	16	6	4,9	3	5,1	◀
5/16	18	7,938	63	19	6	4,9	3	6,6	
3/8	16	9,525	70	22	7	5,5	3	8	
7/16	14	11,113	70	22	8	6,2	3	9,4	
1/2	13	12,700	75	28	9	7	3	10,8	
9/16	12	14,288	80	30	11	9	4	12,2	
5/8	11	15,875	80	30	12	9	4	13,5	
3/4	10	19,050	95	34	14	11	4	16,5	
7/8	9	22,225	100	34	18	14,5	4	19,5	
1"	8	25,400	110	38	18	14,5	4	22,25	
1 1/8	7	28,575	125	45	22	18	4	25	
1 1/4	7	31,750	125	45	22	18	4	28	
1 3/8	6	34,925	150	55	28	22	4	30,75	
1 1/2	6	38,100	150	55	28	22	4	34	
1 3/4	5	44,450	160	60	36	29	5	39,5	
2"	4 1/2	50,800	180	65	40	32	5	45	

01UNC...	CODICE - CODE			
	02UNC...	03UNC...	00UNC...	
◊	◊	◊	◊	
◊	◊	◊	◊	
◊	◊	◊	◊	
◊	◊	◊	◊	
◊	◊	◊	◊	
◊	◊	◊	◊	
◊	◊	◊	◊	
◊	◊	◊	◊	
◊	◊	◊	◊	
◊	◊	◊	◊	
◊	◊	◊	◊	
◊	◊	◊	◊	
◊	◊	◊	◊	
◊	◊	◊	◊	
◊	◊	◊	◊	
◊	◊	◊	◊	
◊	◊	◊	◊	
◊	◊	◊	◊	
◊	◊	◊	◊	
◊	◊	◊	◊	
◊	◊	◊	◊	
◊	◊	◊	◊	
◊	◊	◊	◊	
◊	◊	◊	◊	
◊	◊	◊	◊	
◊	◊	◊	◊	
◊	◊	◊	◊	
◊	◊	◊	◊	
◊	◊	◊	◊	
◊	◊	◊	◊	
◊	◊	◊	◊	
◊	◊	◊	◊	
◊	◊	◊	◊	
◊	◊	◊	◊	
◊	◊	◊	◊	

Ad esaurimento scorte
Stock clearance - Stock épuisé

Confezione: Singola Box: Single Colis: Unique	€ Pag. listino - Price list - Liste des prix ● Standard	72	72	72	72
	◊ Disponibilità da richiedere, prezzo a listino On enquiry, standard price-list / Stock à vérifier			★ Solo a richiesta Only on request / Sur demande	

N **USO GENERALE**
General purpose - Usage Général

DIN 371

DIN 376

DIN 376

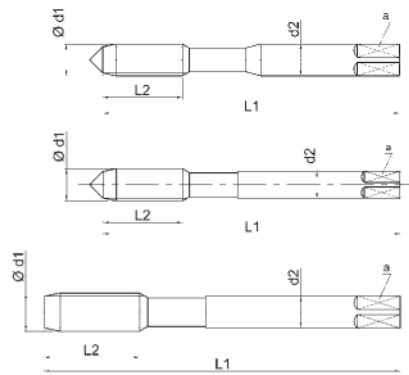

UNC

60° P
RH
C 2-3
Rm 850

Profond. di filettatura - Thread depth - Profond. de filetage	1,5xD	1,5xD
Materiale - Material - Matériau	HSSE	HSSE
Tolleranza - Tolerance - Tolérance	2B	2B
Trattamento superficiale - Surface treatment - Revêtement	BR	TiN
Numero gruppi materiali Material's groups number Nombre de groupes du matériau	1.1 1.2 1.3 1.4 3.4 4.2 4.3 5.2 5.3 8.2	1.1 1.2 1.3 1.4 3.4 4.2 4.3 5.2 5.3 8.2

DIN 371	Ød1 UNC	P TPI	Ø mm	L ₁	L ₂	d ₂ h9	a h12	Z	
◀	6	32	3,505	56	11	4	3	3	2,85
◀	8	32	4,166	63	13	4,5	3,4	3	3,5
◀	10	24	4,826	70	13	6	4,9	3	3,9
◀	12	24	5,486	80	16	6	4,9	3	4,5
◀	1/4	20	6,350	80	16	7	5,5	3	5,1
◀	5/16	18	7,938	90	18	8	6,2	3	6,6
◀	3/8	16	9,525	100	20	10	8	3	8

CODICE - CODE	
E20UNC...	E20UNC...T
●	○
●	○
●	○
○	○
●	○
○	○
○	○

DIN 376	Ød1 UNC	P TPI	Ø mm	L ₁	L ₂	d ₂ h9	a h12	Z	
◀	1/4	20	6,350	80	16	4,5	3,4	3	5,1
◀	5/16	18	7,938	90	18	6	4,9	3	6,6
◀	3/8	16	9,525	100	20	7	5,5	3	8
	7/16	14	11,113	100	20	8	6,2	3	9,4
	1/2	13	12,700	110	25	9	7	3	10,8
	9/16	12	14,288	110	28	11	9	3	12,2
	5/8	11	15,875	110	28	12	9	3	13,5
	3/4	10	19,050	125	32	14	11	4	16,5
	7/8	9	22,225	140	32	18	14,5	4	19,5
	1"	8	25,400	160	36	18	14,5	4	22,25
	1" 1/8	7	28,575	180	46	22	18	4	25
	1" 1/4	7	31,750	180	46	22	18	4	28
	1" 3/8	6	34,925	200	50	28	22	4	30,75
	1" 1/2	6	38,100	200	50	28	22	4	34
■	1" 3/4	5	44,450	220	60	36	29	5	39,5
■	2"	4 1/2	50,800	250	65	40	32	5	45

CODICE - CODE	
E21UNC...	E21UNC...T
○	○
●	○
●	○
●	○
●	○
○	○
●	○
●	○
○	○
●	○
○	○
●	○
○	○
○	○

■ = Acciaio HSS
HSS Steel / Acier HSS

Confezione: Singola Box: Single Colis: Unique	€ Pag. listino - Price list - Liste des prix	72	73
	● Standard	○ Disponibilità da richiedere, prezzo a listino On enquiry, standard price-list / Stock à vérifier	★ Solo a richiesta Only on request / Sur demande

MASCHI A MACCHINA MACHINE TAPS

DIN 371

DIN 371

DIN 376

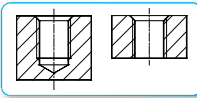
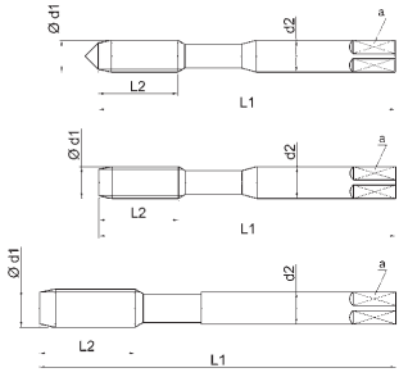

LINE

LINE

TOP

TOP



Profond. di filettatura - Thread depth - Profond. de filetage

Materiale - Material - Matériau

Tolleranza - Tolerance - Tolérance

Trattamento superficiale - Surface treatment - Revêtement

AI Si>10%,
Ottone / Brass / Laiton
Bronzo / Bronze / Bronze
truciolo corto / short chip /
coupeaux courts

Numero gruppi materiali
Material's groups number
Nombre de groupes du matériau

3xD	3xD	3xD	3,5xD
HSSE	HSSE	PM3	PM3
2BX	2BX	2BX	2BX
NQ	TiCN	TiAlN	TiAlN
3.1 3.2 3.3 3.4 3.5	3.1 3.2 3.3 3.4 3.5	3.1 3.2 3.3 3.4 3.5	3.1 3.2 3.3 3.4 3.5
4.3 4.4 4.5 4.6 5.3	4.3 4.4 4.5 4.6 5.3	4.4 5.3 5.4	4.4 5.3 5.4
8.2 10.1	8.2 10.1	10.1	10.1

DIN 371	Ød1 UNC	P TPI	Ø mm	L ₁	L ₂	d ₂ h9	a h12	Z	Image
6	32	3,505	56	11	4	3	3	2,85	Image
8	32	4,166	63	13	4,5	3,4	3	3,5	Image
10	24	4,826	70	13	6	4,9	3	3,9	Image
12	24	5,486	80	16	6	4,9	3	4,5	Image
1/4	20	6,350	80	16	7	5,5	3	5,1	Image
1/4	20	6,350	80	16	7	5,5	4	5,1	Image
5/16	18	7,938	90	18	8	6,2	4	6,6	Image
3/8	16	9,525	100	20	10	8	4	8	Image
1/4	20	6,350	80	16	7	5,5	3	5,1	Image
1/4	20	6,350	80	16	7	5,5	4	5,1	Image

CODICE - CODE			
E26UNC...NQ	E26UNC...CT	K26UNC...TX	
*	○	-	-
*	○	-	-
*	●	-	-
*	○	-	-
*	●	-	-
-	-	○	-
-	-	○	-
-	-	○	-
E26UNC...SP-NQ	E26UNC...SP-CT	K26UNC...SP-TX	K26UNC...FOR-TX
*	○	-	-
-	-	○	○

DIN 376	Ød1 UNC	P TPI	Ø mm	L ₁	L ₂	d ₂ h9	a h12	Z	Image
5/16	18	7,938	90	18	6	4,9	4	6,6	Image
3/8	16	9,525	100	20	7	5,5	4	8	Image
7/16	14	11,113	100	20	8	6,2	4	9,4	Image
1/2	13	12,700	110	25	9	7	4	10,8	Image
9/16	12	14,288	110	28	11	9	4	12,2	Image
5/8	11	15,875	110	28	12	9	4	13,5	Image
3/4	10	19,050	125	32	14	11	4	16,5	Image
7/8	9	22,225	140	32	18	14,5	4	19,5	Image
1"	8	25,400	160	36	18	14,5	4	22,25	Image
3/4	10	19,050	125	32	14	11	5	16,5	Image
7/8	9	22,225	140	32	18	14,5	5	19,5	Image
1"	8	25,400	160	36	18	14,5	5	22,25	Image

CODICE - CODE			
E27UNC...NQ	E27UNC...CT	K27UNC...TX	K27UNC...FOR-TX
*	●	-	-
*	●	-	-
*	●	○	○
*	●	○	○
*	○	○	○
*	○	○	○
*	○	-	-
*	○	-	-
*	○	-	-
*	○	-	-
-	-	○	○
-	-	○	○
-	-	○	○

Confezione / Box / Colis:
6 - 7/16: 10 pezzi / pcs
1/2 - 9/16: 5 pezzi / pcs
>9/16: singoli / single pcs

€ Pag. listino - Price list - Liste des prix

73

73

73

73

● Standard

○ Disponibilità da richiedere, prezzo a listino
On enquiry, standard price-list / Stock à vérifier

* Solo a richiesta
Only on request / Sur demande

N **USO GENERALE**
General purpose

MASCHI A MACCHINA MACHINE TAPS

DIN 371

DIN 376

DIN 376

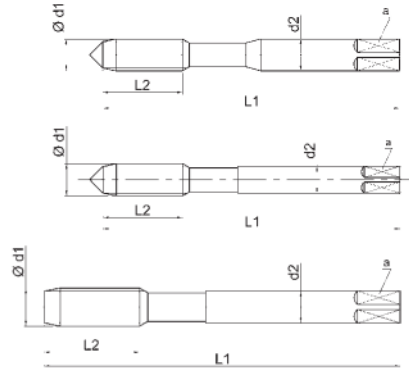

UNC

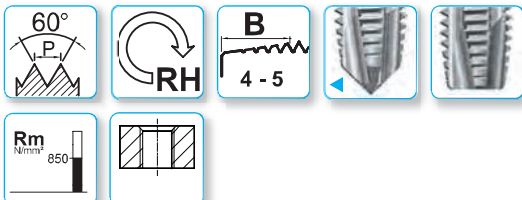

Profond. di filettatura - Thread depth - Profond. de filetage	3xD	3xD	3xD	3xD
Materiale - Material - Matériau	HSSE	HSSE	HSSE	HSSE
Tolleranza - Tolerance - Tolérance	2B	2B	2B	2B
Trattamento superficiale - Surface treatment - Revêtement	BR	V	TiN	XP
Numero gruppi materiali Material's groups number Nombre de groupes du matériau	1.1 1.2 1.3 1.4	1.1 1.2 1.3 1.4	1.1 1.2 1.3 1.4	1.1 1.2 1.3 1.4
	4.1 4.2	4.1 4.2	3.3 3.4	2.1 2.2 3.3 3.4
	5.1 5.2	5.1 5.2	4.1 4.2 4.3	4.2 4.3
		6.1 7.1	5.1 5.2	5.2

DIN 371	Ød1 UNC	P TPI	Ø mm	L ₁	L ₂	d ₂ h9	a h12	Z	
◀	6	32	3,505	56	11	4	3	3	2,85
◀	8	32	4,166	63	13	4,5	3,4	3	3,5
◀	10	24	4,826	70	13	6	4,9	3	3,9
◀	12	24	5,486	80	16	6	4,9	3	4,5
◀	1/4	20	6,350	80	16	7	5,5	3	5,1
◀	5/16	18	7,938	90	18	8	6,2	3	6,6
◀	3/8	16	9,525	100	20	10	8	3	8

CODICE - CODE			
E24UNC...	E24UNC...V	E24UNC...T	E24UNC...XP
•	○	○	○
•	○	○	○
•	○	○	○
○	○	○	○
•	○	○	○
○	○	○	○
○	○	○	○

DIN 376	Ød1 UNC	P TPI	Ø mm	L ₁	L ₂	d ₂ h9	a h12	Z	
◀	1/4	20	6,350	80	16	4,5	3,4	3	5,1
◀	5/16	18	7,938	90	18	6	4,9	3	6,6
◀	3/8	16	9,525	100	20	7	5,5	3	8
	7/16	14	11,113	100	20	8	6,2	3	9,4
	1/2	13	12,700	110	25	9	7	3	10,8
	9/16	12	14,288	110	28	11	9	3	12,2
	5/8	11	15,875	110	28	12	9	3	13,5
	3/4	10	19,050	125	32	14	11	4	16,5
	7/8	9	22,225	140	32	18	14,5	4	19,5
	1"	8	25,400	160	36	18	14,5	4	22,25
	1" 1/8	7	28,575	180	46	22	18	4	25
	1" 1/4	7	31,750	180	46	22	18	4	28
	1" 3/8	6	34,925	200	50	28	22	4	30,75
	1" 1/2	6	38,100	200	50	28	22	4	34
■	1" 3/4	5	44,450	220	60	36	29	5	39,5
■	2"	4 1/2	50,800	250	65	40	32	5	45

CODICE - CODE			
E25UNC...	E25UNC...V	E25UNC...T	E25UNC...XP
○	○	○	○
•	○	○	○
•	○	○	○
•	○	○	○
•	○	○	○
○	○	○	○
•	○	○	○
○	○	○	○
•	○	○	○
○	○	○	○
○	○	○	○
○	○	○	○

■ = Acciaio HSS / HSS Steel / Acier HSS	€ Pag. listino - Price list - Liste des prix	74	74	74	74
Confezione / Box / Colis: 6 - 7/16: 10 pezzi / pcs 1/2 - 9/16: 5 pezzi / pcs >9/16: singoli / single pcs	● Standard	○ Disponibilità da richiedere, prezzo a listino On enquiry, standard price-list / Stock à vérifier	○	★ Solo a richiesta Only on request / Sur demande	○

MASCHI A MACCHINA

MACHINE TAPS - TARAUDS MACHINE

DIN 371

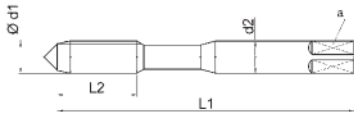

DIN 376

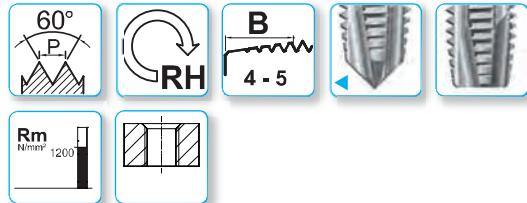
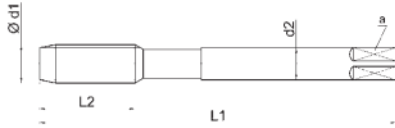

Profond. di filettatura - Thread depth - Profond. de filetage
 Materiale - Material - Matériau
 Tolleranza - Tolerance - Tolérance
 Trattamento superficiale - Surface treatment - Revêtement

3xD **3xD**
PM3 **PM3**
2BX **2BX**
XP **XP**

Numero gruppi materiali
 Material's groups number
 Nombre de groupes du matériau

1.1 1.2 1.3 1.4 1.5
 2.1 2.2 2.3
 3.3 3.4 4.2 4.3
 5.2

DIN 371	Ød1 UNC	P TPI	Ø mm	L ₁	L ₂	d ₂ h9	a h12	Z	
4	40	2,845	56	10	3,5	2,7	3	2,35	
5	40	3,175	56	10	3,5	2,7	3	2,65	
6	32	3,505	56	11	4	3	3	2,85	
8	32	4,166	63	13	4,5	3,4	3	3,5	
10	24	4,826	70	13	6	4,9	3	3,9	
1/4	20	6,350	80	16	7	5,5	3	5,1	
5/16	18	7,938	90	18	8	6,2	3	6,6	
3/8	16	9,525	100	20	10	8	3	8	

CODICE - CODE	
K24UNC...XP	K24UNC...FORY-XP
○	-
○	-
○	-
○	-
○	-
○	○
○	○
○	○

DIN 376	Ød1 UNC	P TPI	Ø mm	L ₁	L ₂	d ₂ h9	a h12	Z	
7/16	14	11,113	100	20	8	6,2	3	9,4	
1/2	13	12,700	110	25	9	7	4	10,8	
9/16	12	14,288	110	28	11	9	4	12,2	
5/8	11	15,875	110	28	12	9	4	13,5	
3/4	10	19,050	125	32	14	11	4	16,5	
7/8	9	22,225	140	32	18	14,5	4	19,5	
1"	8	25,400	160	36	18	14,5	4	22,25	

CODICE - CODE	
K25UNC...XP	K25UNC...FORY-XP
○	○
○	○
○	○
○	○
○	○
○	○

Confezione / Box / Colis: 6 - 7/16: 10 pezzi / pcs; 1/2 - 9/16: 5 pezzi / pcs; >9/16: singoli / single pcs

€ Pag. listino - Price list - Liste des prix **75** **75**

● Standard ○ Disponibilità da richiedere, prezzo a listino / On enquiry, standard price-list / Stock à vérifier ★ Solo a richiesta / Only on request / Sur demande

INOX

ACCIAIO INOSSIDABILE

Stainless steel - Acier inoxydable

MASCHI A MACCHINA

MACHINE TAPS - TARAUDS MACHINE

DIN 371

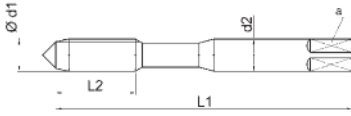

DIN 376

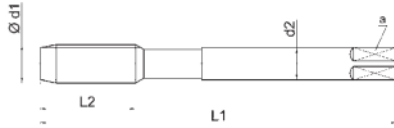

TOP

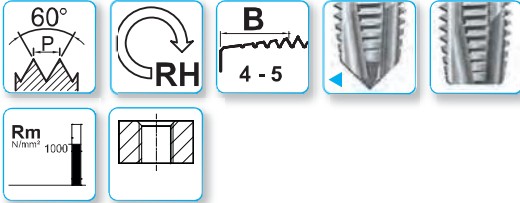

Profond. di filettatura - Thread depth - Profond. de filetage

3xD

Materiale - Material - Matériau

HSSV3

Tolleranza - Tolerance - Tolérance

2BX

Trattamento superficiale - Surface treatment - Revêtement

TXC

Numero gruppi materiali

Material's groups number

Nombre de groupes du matériau

1.3 1.4 1.5

2.1 2.2 2.3 2.4

DIN 371	Ød1 UNC	P TPI	Ø mm	L ₁	L ₂	d ₂ h9	a h12	Z	
◀	6	32	3,505	56	11	4	3	3	2,85
◀	8	32	4,166	63	13	4,5	3,4	3	3,5
◀	10	24	4,826	70	13	6	4,9	3	3,9
◀	1/4	20	6,350	80	16	7	5,5	3	5,1
◀	5/16	18	7,938	90	18	8	6,2	3	6,6
◀	3/8	16	9,525	100	20	10	8	3	8

V24UNC...TXC

CODICE - CODE

DIN 376	Ød1 UNC	P TPI	Ø mm	L ₁	L ₂	d ₂ h9	a h12	Z	
	7/16	14	11,113	100	20	8	6,2	3	9,4
	1/2	13	12,700	110	25	9	7	4	10,8
	9/16	12	14,288	110	28	11	9	4	12,2
	5/8	11	15,875	110	28	12	9	4	13,5
	3/4	10	19,050	125	32	14	11	4	16,5
	7/8	9	22,225	140	32	18	14,5	4	19,5
	1"	8	25,400	160	36	18	14,5	4	22,25

V25UNC...TXC

CODICE - CODE

Confezione / Box / Colis:
6 - 7/16: 10 pezzi / pcs
1/2 - 9/16: 5 pezzi / pcs
>9/16: singoli / single pcs

€ Pag. listino - Price list - Liste des prix

75

● Standard

○ Disponibilità da richiedere, prezzo a listino
On enquiry, standard price-list / Stock à vérifier

★ Solo a richiesta
Only on request / Sur demande

UNC

Filettatura americana UNC passo grosso ASME B1.1

UNC coarse thread ASME B1.1

Unified Grobgewinde UNC ASME B1.1 – Maschinengewindebohrer

Filetage américain UNC ASME B1.1 – Tarauds machine

Rosca gruesa UNC ASME B1.1 – Machos de roscar a máquina



Ti

TITANIO

Titanium - Titane

MASCHI A MACCHINA

MACHINE TAPS - TARAUDS MACHINE

DIN 371

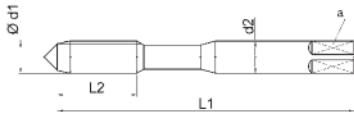

DIN 376

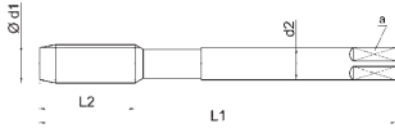

TOP



L15°

TOP



L15°

TOP



L15°

Profond. di filettatura - Thread depth - Profond. de filetage

Materiale - Material - Matériau

Tolleranza - Tolerance - Tolérance

Trattamento superficiale - Surface treatment - Revêtement

Numero gruppi materiali

Material's groups number

Nombre de groupes du matériau

3xD	3xD	3xD
PM3	PM3	PM3
2BX	2BX	3BX
V	TiCN	V
6.1	1.6 2.4	6.1
	3.3 3.4	
	4.4 5.3 5.4 6.2 6.3	
	7.2 9.2	

DIN 371	$\varnothing d_1$ UNC	P TPI	\varnothing mm	L_1	L_2	d_2 h9	a h12	Z	
◀	6	32	3,505	56	11	4	3	3	*2,85
◀	8	32	4,166	63	13	4,5	3,4	3	*3,5
◀	10	24	4,826	70	13	6	4,9	3	*3,9
◀	1/4	20	6,350	80	16	7	5,5	3	*5,1
◀	5/16	18	7,938	90	18	8	6,2	3	*6,6
◀	3/8	16	9,525	100	20	10	8	3	*8

CODICE - CODE		
K52UNC...V	K52UNC...CT	K52UNC...V-3BX
○	○	○
○	○	○
○	○	○
○	○	○
○	○	○
○	○	○
○	○	○
○	○	○
○	○	○
○	○	○
○	○	○
○	○	○
○	○	○
○	○	○
○	○	○

DIN 376	$\varnothing d_1$ UNC	P TPI	\varnothing mm	L_1	L_2	d_2 h9	a h12	Z	
new	7/16	14	11,113	100	20	8	6,2	3	*9,4
	1/2	13	12,700	110	25	9	7	3	*10,8
	5/8	11	15,875	110	28	12	9	3	*13,5
	3/4	10	19,050	125	32	14	11	4	*16,5

CODICE - CODE		
K53UNC...V	K53UNC...CT	K53UNC...V-3BX
○	○	○
○	○	○
○	○	○
○	○	○
○	○	○
○	○	○
○	○	○
○	○	○
○	○	○
○	○	○
○	○	○
○	○	○
○	○	○
○	○	○
○	○	○
○	○	○

* Per UNJC vedi tabella di foratura pag. 254
 * Drills' diameters for UNJC: table page 254
 * Pour UNJC voir le tableau de perçage page 254

Confezione / Box / Colis: 6 - 7/16: 10 pezzi / pcs 1/2 - 9/16: 5 pezzi / pcs >9/16: singoli / single pcs	€ Pag. listino - Price list - Liste des prix ● Standard	75 ○ Disponibilità da richiedere, prezzo a listino On enquiry, standard price-list / Stock à vérifier	75 ○ Solo a richiesta Only on request / Sur demande	76 ○ Solo a richiesta Only on request / Sur demande
---	--	---	---	---

N **USO GENERALE**
General purpose - Usage Général

MASCHI A MACCHINA
MACHINE TAPS - TARAUDS MACHINE

DIN 371

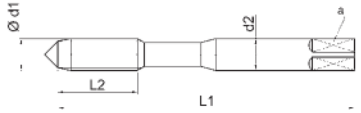

DIN 376

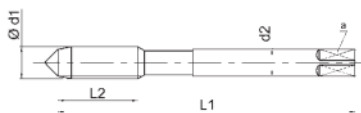

DIN 376

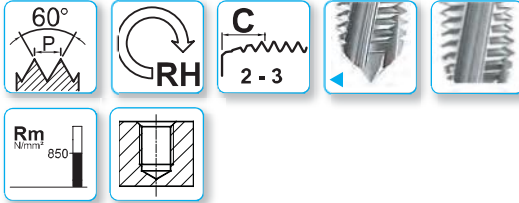
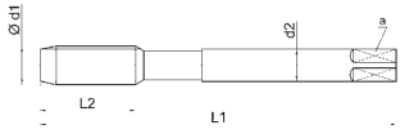

UNC

Profond. di filettatura - Thread depth - Profond. de filetage
Materiale - Material - Matériau
Tolleranza - Tolerance - Tolérance
Trattamento superficiale - Surface treatment - Revêtement

1,5xD	1,5xD	1,5xD	1,5xD
HSSE	HSSE	HSSE	HSSE
2B	2B	2B	2B
BR	V	TiN	XP

Numero gruppi materiali
Material's groups number
Nombre de groupes du matériau

1.1 1.2 1.3 1.4	1.1 1.2 1.3 1.4	1.1 1.2 1.3 1.4	1.1 1.2 1.3 1.4
4.1 4.2	4.1 4.2	3.3 3.4	3.3 3.4
5.1 5.2	5.1 5.2	4.1 4.2 4.3	4.2 4.3
	6.1 7.1	5.1 5.2	5.2

DIN 371	Ød1 UNC	P TPI	Ø mm	L ₁	L ₂	d ₂ h9	a h12	Z	
◀	6	32	3,505	56	11	4	3	3	2,85
◀	8	32	4,166	63	13	4,5	3,4	3	3,5
◀	10	24	4,826	70	13	6	4,9	3	3,9
◀	12	24	5,486	80	16	6	4,9	3	4,5
◀	1/4	20	6,350	80	16	7	5,5	3	5,1
◀	5/16	18	7,938	90	18	8	6,2	3	6,6
◀	3/8	16	9,525	100	20	10	8	3	8

CODICE - CODE			
E40UNC...	E40UNC...V	E40UNC...T	E40UNC...XP
•	◊	◊	◊
•	◊	◊	◊
•	◊	◊	◊
◊	◊	◊	◊
•	◊	◊	◊
◊	◊	◊	◊
◊	◊	◊	◊

DIN 376	Ød1 UNC	P TPI	Ø mm	L ₁	L ₂	d ₂ h9	a h12	Z	
◀	1/4	20	6,350	80	16	4,5	3,4	3	5,1
◀	5/16	18	7,938	90	18	6	4,9	3	6,6
◀	3/8	16	9,525	100	20	7	5,5	3	8
	7/16	14	11,113	100	20	8	6,2	3	9,4
	1/2	13	12,700	110	25	9	7	3	10,8
	9/16	12	14,288	110	28	11	9	3	12,2
	5/8	11	15,875	110	28	12	9	3	13,5
	3/4	10	19,050	125	32	14	11	4	16,5
	7/8	9	22,225	140	32	18	14,5	4	19,5
	1"	8	25,400	160	36	18	14,5	4	22,25
	1" 1/8	7	28,575	180	46	22	18	4	25
	1" 1/4	7	31,750	180	46	22	18	4	28
	1" 3/8	6	34,925	200	50	28	22	4	30,75
	1" 1/2	6	38,100	200	50	28	22	4	34
■	1" 3/4	5	44,450	220	60	36	29	5	39,5
■	2"	4 1/2	50,800	250	65	40	32	5	45

CODICE - CODE			
E41UNC...	E41UNC...V	E41UNC...T	E41UNC...XP
◊	◊	◊	◊
•	◊	◊	◊
•	◊	◊	◊
•	◊	◊	◊
•	◊	◊	◊
◊	◊	◊	◊
•	◊	◊	◊
•	◊	◊	◊
◊	◊	◊	◊
•	◊	◊	◊
◊	◊	◊	◊
•	◊	◊	◊
◊	◊	◊	◊
◊	◊	◊	◊

■ = Acciaio HSS / HSS Steel / Acier HSS

Confezione / Box / Colis: 6 - 7/16: 10 pezzi / pcs 1/2 - 9/16: 5 pezzi / pcs >9/16: singoli / single pcs	€ Pag. listino - Price list - Liste des prix	76	76	76	77
	• Standard	◊ Disponibilità da richiedere, prezzo a listino On enquiry, standard price-list / Stock à vérifier		★ Solo a richiesta Only on request / Sur demande	

MASCHI A MACCHINA

MACHINE TAPS - TARAUDS MACHINE

DIN 371

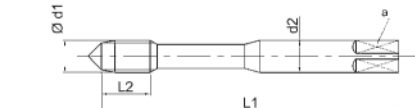

DIN 371

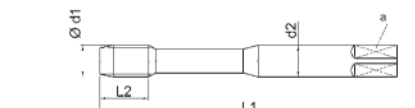

DIN 376

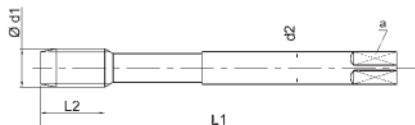

TOP



R15°

TOP



R15°

TOP



R15°

Profond. di filettatura - Thread depth - Profond. de filetage

Materiale - Material - Matériau

Tolleranza - Tolerance - Tolérance

Trattamento superficiale - Surface treatment - Revêtement

Numero gruppi materiali

Material's groups number

Nombre de groupes du matériau

1,5xD	1,5xD	1,5xD
PM3	PM3	PM3
2BX	2BX	3BX
V	TiCN	V
6.1	1.6 2.4	6.1
	3.3 3.4	
	4.4 5.3 5.4 6.2 6.3	
	7.2 9.2	

DIN 371	Ød1 UNC	P TPI	Ø mm	L ₁	L ₂	d ₂ h9	a h12	Z	
6	32	3,505	56	7	4	3	3	*2,85	
8	32	4,166	63	7	4,5	3,4	3	*3,5	
10	24	4,826	70	8	6	4,9	3	*3,9	
1/4	20	6,350	80	10	7	5,5	3	*5,1	
5/16	18	7,938	90	13	8	6,2	3	*6,6	
3/8	16	9,525	100	15	10	8	3	*8	

CODICE - CODE		
K42UNC...V	K42UNC...CT	K42UNC...V-3BX
⌋	⌋	⌋
⌋	⌋	⌋
⌋	⌋	⌋
⌋	⌋	⌋
⌋	⌋	⌋
⌋	⌋	⌋

DIN 376	Ød1 UNC	P TPI	Ø mm	L ₁	L ₂	d ₂ h9	a h12	Z	
7/16	14	11,113	100	15	8	6,2	4	*9,4	
1/2	13	12,700	110	18	9	7	4	*10,8	
5/8	11	15,875	110	20	12	9	4	*13,5	
3/4	10	19,050	125	25	14	11	4	*16,5	

CODICE - CODE		
K43UNC...V	K43UNC...CT	K43UNC...V-3BX
⌋	⌋	⌋
⌋	⌋	⌋
⌋	⌋	⌋
⌋	⌋	⌋

* Per UNJC vedi tabella di foratura pag. 254
 * Drills' diameters for UNJC: table page 254
 * Pour UNJC voir le tableau de perçage page 254

Confezione / Box / Colis: 6 - 7/16: 10 pezzi / pcs 1/2 - 9/16: 5 pezzi / pcs >9/16: singoli / single pcs	€ Pag. listino - Price list - Liste des prix	77	77	77
● Standard	⌋ Disponibilità da richiedere, prezzo a listino On enquiry, standard price-list / Stock à vérifier			* Solo a richiesta Only on request / Sur demande

N **USO GENERALE**
General purpose - Usage Général

MASCHI A MACCHINA
MACHINE TAPS - TARAUDS MACHINE

DIN 371

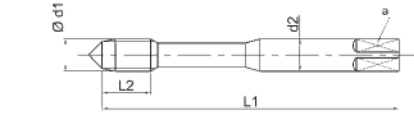

DIN 376

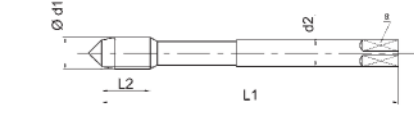

DIN 376

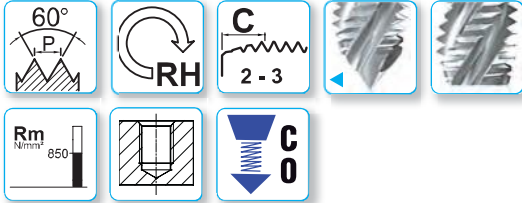
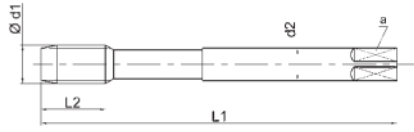

UNC

Profond. di filettatura - Thread depth - Profond. de filetage
Materiale - Material - Matériau
Tolleranza - Tolerance - Tolérance
Trattamento superficiale - Surface treatment - Revêtement

2,5xD	2,5xD	2,5xD	2,5xD
HSSE	HSSE	HSSE	HSSE
2B	2B	2B	2B
BR	V	TiN	XP

Numero gruppi materiali
Material's groups number
Nombre de groupes du matériau

1.1 1.2 1.3 1.4	1.1 1.2 1.3 1.4	1.1 1.2 1.3 1.4	1.1 1.2 1.3 1.4
4.1 4.2	4.1 4.2	3.3 3.4	2.1 2.2 3.3 3.4
5.1 5.2	5.1 5.2	4.1 4.2 4.3	4.2 4.3
		5.1 5.2	5.2

DIN 371	Ød1 UNC	P TPI	Ø mm	L ₁	L ₂	d ₂ h9	a h12	Z	
◀	6	32	3,505	56	7	4	3	3	2,85
◀	8	32	4,166	63	7	4,5	3,4	3	3,5
◀	10	24	4,826	70	8	6	4,9	3	3,9
◀	12	24	5,486	80	10	6	4,9	3	4,5
◀	1/4	20	6,350	80	10	7	5,5	3	5,1
	5/16	18	7,938	90	13	8	6,2	3	6,6
	3/8	16	9,525	100	15	10	8	3	8

CODICE - CODE			
E60UNC...	E60UNC...V	E60UNC...T	E60UNC...XP
•	○	○	○
•	○	○	○
•	○	○	○
○	○	○	○
•	○	○	○
○	○	○	○
○	○	○	○

DIN 376	Ød1 UNC	P TPI	Ø mm	L ₁	L ₂	d ₂ h9	a h12	Z	
◀	1/4	20	6,350	80	10	4,5	3,4	3	5,1
	5/16	18	7,938	90	13	6	4,9	3	6,6
	3/8	16	9,525	100	15	7	5,5	3	8
	7/16	14	11,113	100	15	8	6,2	3	9,4
	1/2	13	12,700	110	18	9	7	3	10,8
	9/16	12	14,288	110	20	11	9	4	12,2
	5/8	11	15,875	110	20	12	9	4	13,5
	3/4	10	19,050	125	25	14	11	4	16,5
	7/8	9	22,225	140	25	18	14,5	4	19,5
	1"	8	25,400	160	30	18	14,5	4	22,25
	1" 1/8	7	28,575	180	35	22	18	4	25
	1" 1/4	7	31,750	180	35	22	18	4	28
	1" 3/8	6	34,925	200	40	28	22	4	30,75
	1" 1/2	6	38,100	200	40	28	22	4	34
■	1" 3/4	5	44,450	220	50	36	29	5	39,5
■	2"	4 1/2	50,800	250	55	40	32	5	45

CODICE - CODE			
E61UNC...	E61UNC...V	E61UNC...T	E61UNC...XP
○	○	○	○
•	○	○	○
•	○	○	○
•	○	○	○
•	○	○	○
○	○	○	○
•	○	○	○
•	○	○	○
○	○	○	○
•	○	○	○
○	○	○	○
○	○	○	○
○	○	○	○
○	○	○	○

Confezione / Box / Colis: 6 - 7/16: 10 pezzi / pcs 1/2 - 9/16: 5 pezzi / pcs >9/16: singoli / single pcs	€ Pag. listino - Price list - Liste des prix	77	78	78	78
	• Standard	○ Disponibilità da richiedere, prezzo a listino On enquiry, standard price-list/ Stock à vérifier		★ Solo a richiesta Only on request / Sur demande	

MASCHI A MACCHINA

MACHINE TAPS - TARAUDS MACHINE

DIN 371

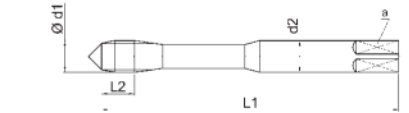

DIN 371

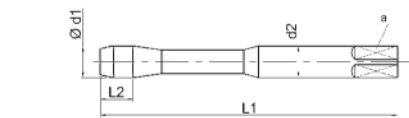

DIN 376

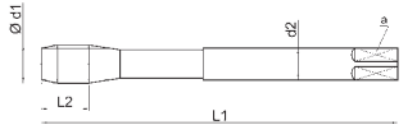

60°
P

RH

C
2-3

Rm
N/mm² 1200

Back Tapered
BT

SR

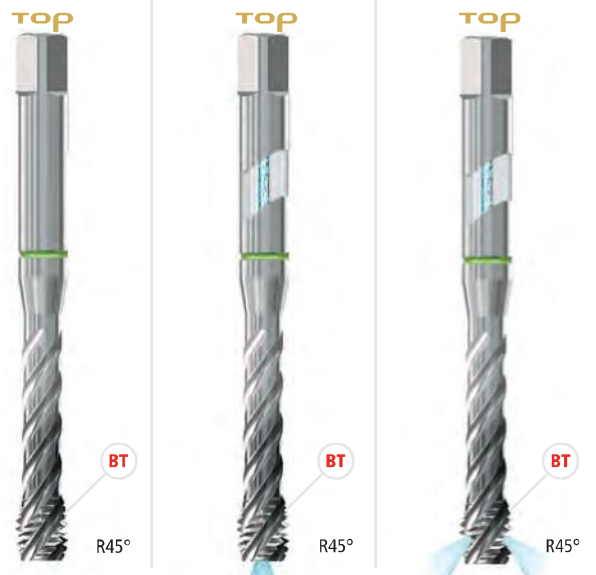

Profond. di filettatura - Thread depth - Profond. de filetage
 Materiale - Material - Matériau
 Tolleranza - Tolerance - Tolérance
 Trattamento superficiale - Surface treatment - Revêtement

3xD	3,5xD	3,5xD
PM3	PM3	PM3
2BX	2BX	2BX
XP	XP	XP
1.1 1.2 1.3 1.4 1.5	1.1 1.2 1.3 1.4 1.5	1.1 1.2 1.3 1.4 1.5
2.1 2.2 2.3	2.1 2.2 2.3	2.1 2.2 2.3
3.3 3.4 4.2 4.3	3.3 3.4 4.2 4.3	3.3 3.4 4.2 4.3
5.2	5.2	5.2

Numero gruppi materiali
 Material's groups number
 Nombre de groupes du matériau

DIN 371	Ød1 UNC	P TPI	Ø mm	L ₁	L ₂	d ₂ h9	a h12	Z	
4	40	2,845	56	5	3,5	2,7	3	2,35	
5	40	3,175	56	5	3,5	2,7	3	2,65	
6	32	3,505	56	7	4	3	3	2,85	
8	32	4,166	63	7	4,5	3,4	3	3,5	
10	24	4,826	70	8	6	4,9	3	3,9	
1/4	20	6,350	80	10	7	5,5	3	5,1	
5/16	18	7,938	90	13	8	6,2	3	6,6	
3/8	16	9,525	100	15	10	8	3	8	

K82UNC...XP	CODICE - CODE	
	K82UNC...FOR-XP	K82UNC...FOR-XP
○	-	-
○	-	-
○	-	-
○	-	-
○	-	-
○	○	○
○	○	○
○	○	○
○	○	○

DIN 376	Ød1 UNC	P TPI	Ø mm	L ₁	L ₂	d ₂ h9	a h12	Z	
7/16	14	11,113	100	15	8	6,2	3	9,4	
1/2	13	12,700	110	18	9	7	4	10,8	
9/16	12	14,288	110	20	11	9	4	12,2	
5/8	11	15,875	110	20	12	9	4	13,5	
3/4	10	19,050	125	25	14	11	4	16,5	
7/8	9	22,225	140	25	18	14,5	4	19,5	
1"	8	25,400	160	30	18	14,5	4	22,25	

K83UNC...XP	CODICE - CODE	
	K83UNC...FOR-XP	K83UNC...FOR-XP
○	○	○
○	○	○
○	○	○
○	○	○
○	○	○
○	○	○
○	○	○

RACCOMANDATO per filettatura rigida
 We recommend Syncro rigid threading
 Recommandé pour le taraudage rigide

Confezione / Box / Colis: 6 - 7/16: 10 pezzi / pcs 1/2 - 9/16: 5 pezzi / pcs >9/16: singoli / single pcs	€ Pag. listino - Price list - Liste des prix	79	79	79
● Standard	○ Disponibilità da richiedere, prezzo a listino On enquiry, standard price-list / Stock à vérifier	★ Solo a richiesta Only on request / Sur demande		

INOX

ACCIAIO INOSSIDABILE

Stainless steel - Acier inoxydable

MASCHI A MACCHINA

MACHINE TAPS - TARAUDS MACHINE

DIN 371

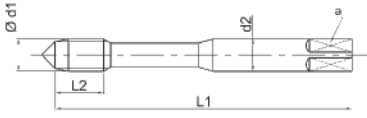

DIN 371

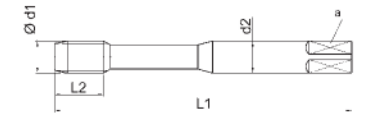

DIN 376

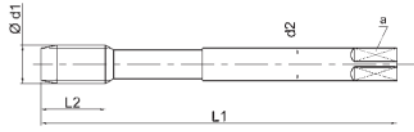

TOP



R48°

60° P RH C 2-3 Rm Nitem 1000 SR

Profond. di filettatura - Thread depth - Profond. de filetage

3,5xD

Materiale - Material - Matériau

HSSV3

Tolleranza - Tolerance - Tolérance

2BX

Trattamento superficiale - Surface treatment - Revêtement

TXC

Numero gruppi materiali

Material's groups number

Nombre de groupes du matériau

1.3 1.4 1.5

2.1 2.2 2.3 2.4

DIN 371	Ød1 UNC	P TPI	Ø mm	L ₁	L ₂	d ₂ h9	a h12	Z	
◀	6	32	3,505	56	7	4	3	3	2,85
◀	8	32	4,166	63	7	4,5	3,4	3	3,5
◀	10	24	4,826	70	8	6	4,9	3	3,9
◀	1/4	20	6,350	80	10	7	5,5	3	5,1
	5/16	18	7,938	90	13	8	6,2	3	6,6
	3/8	16	9,525	100	15	10	8	3	8

CODICE - CODE	
V82UNC...TXC	◊
	◊
	◊
	◊
	◊
	◊

DIN 376	Ød1 UNC	P TPI	Ø mm	L ₁	L ₂	d ₂ h9	a h12	Z	
	7/16	14	11,113	100	15	8	6,2	3	9,4
	1/2	13	12,700	110	18	9	7	3	10,8
	9/16	12	14,288	110	20	11	9	4	12,2
	5/8	11	15,875	110	20	12	9	4	13,5
	3/4	10	19,050	125	25	14	11	4	16,5
	7/8	9	22,225	140	25	18	14,5	4	19,5
	1"	8	25,400	160	30	18	14,5	4	22,25

CODICE - CODE	
V83UNC...TXC	◊
	◊
	◊
	◊
	◊
	◊

RACCOMANDATO per filettatura rigida
We recommend Syncro rigid threading
Recommandé pour le taraudage rigide



Confezione / Box / Colis:
6 - 7/16: 10 pezzi / pcs
1/2 - 9/16: 5 pezzi / pcs
>9/16: singoli / single pcs

€ Pag. listino - Price list - Liste des prix

79

• Standard

◊ Disponibilità da richiedere, prezzo a listino
On enquiry, standard price-list / Stock à vérifier

★ Solo a richiesta
Only on request / Sur demande



MASCHI A MACCHINA

MACHINE TAPS - TARAUDS MACHINE

UNC

DIN 371

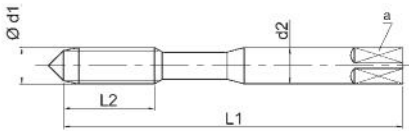

DIN 376

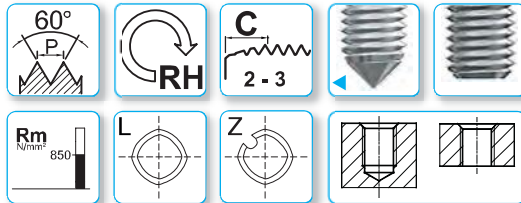
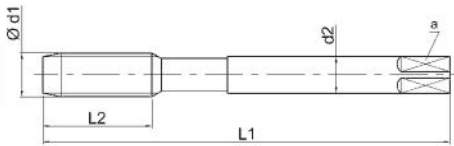

Profond. di filettatura - Thread depth - Profond. de filetage
 Materiale - Material - Matériau
 Tolleranza - Tolerance - Tolérance

3xD	3xD	3xD	3xD
HSSP	HSSP	HSSP	HSSP
2BX	2BX	2BX	2BX
BR	TiN	BR	TiN

Numero gruppi materiali
 Material's groups number
 Nombre de groupes du matériau

1.1 1.2 1.3	1.1 1.2 1.3 1.4	1.1 1.2 1.3	1.1 1.2 1.3 1.4
4.1 4.2	2.1 2.2 2.3	4.1 4.2	2.1 2.2 2.3
	4.1 4.2 4.3		4.1 4.2 4.3
	5.1 5.2		5.1 5.2

DIN 371	Ød1 UNC	P TPI	Ø mm	L ₁	L ₂	d ₂ h9	a h12	Z	
6	32	3,505	56	11	4	3	2	3,15	
8	32	4,166	63	13	4,5	3,4	4	3,8	
10	24	4,826	70	13	6	4,9	4	4,3	
12	24	5,486	80	16	6	4,9	5	5	
1/4	20	6,350	80	16	7	5,5	5	5,75	
5/16	18	7,938	90	18	8	6,2	5	7,25	
3/8	16	9,525	100	20	10	8	5	8,75	

CODICE - CODE			
P2SCUNC...	P2SCUNC...T	P2CCUNC...	P2CCUNC...T
⊘	⊘	⊘	⊘
⊘	⊘	⊘	⊘
⊘	⊘	⊘	⊘
⊘	⊘	⊘	⊘
⊘	⊘	⊘	⊘
⊘	⊘	⊘	⊘
⊘	⊘	⊘	⊘

DIN 376	Ød1 UNC	P TPI	Ø mm	L ₁	L ₂	d ₂ h9	a h12	Z	
7/16	14	11,113	100	20	8	6,2	5	10,3	
1/2	13	12,700	110	25	9	7	5	11,8	
9/16	12	14,288	110	28	11	9	6	13,3	
5/8	11	15,875	110	28	12	9	6	14,8	
3/4	10	19,050	125	32	14	11	6	17,9	

CODICE - CODE			
P2SCUNC...	P2SCUNC...T	P2CCUNC...	P2CCUNC...T
⊘	⊘	⊘	⊘
⊘	⊘	⊘	⊘
⊘	⊘	⊘	⊘
⊘	⊘	⊘	⊘
⊘	⊘	⊘	⊘

Confezione / Box / Colis: M3 – M10: 10 pezzi / pcs M12 – M16: 5 pezzi / pcs	€ Pag. listino - Price list - Liste des prix	79	79	80	80
● Standard	⊘ Disponibilità da richiedere, prezzo a listino On enquiry, standard price-list / Stock à vérifier			★ Solo a richiesta Only on request / Sur demande	

ANSI / ASME B1.2

Calibri a tampone filettati passa / non passa

Thread plug gauges go/no-go

Calibres de filetage entre/n'entre pas



Tolleranza - Tolerance - Tolérance

2B

Trattamento superficiale - Surface treatment - Revêtement

BR

Ød1 UNC	TPI	CODICE - CODE P-NPUNC...
5	40	↷
6	32	↷
8	32	↷
10	24	↷
12	24	↷
1/4	20	↷
5/16	18	↷
3/8	16	↷
7/16	14	↷
1/2	13	↷
9/16	12	↷
5/8	11	↷
3/4	10	↷
7/8	9	↷
1"	8	↷
1" 1/8	7	↷
1" 1/4	7	↷
1" 3/8	6	↷
1" 1/2	6	↷
1" 3/4	5	↷
2"	4,5	↷

