



BRAZED TOOLS EINES SOLDADES

Technical information **A270**
Informació tècnica

Applications index **A271**
Índex d'aplicacions

Toolholders **A272-274**
Portaeines

Boring bars **A275-276**
Barres de mandrinar

Uncoated inserts / Plaquetes no recobertes

KM15

Finishing grade in the K10 range. This carbide grade is for use on cast iron, aluminium and heat-resistant alloys. This grade works well on cobalt based alloys and synthetic materials and is suitable for finishing on heat-resistant alloys.

Qualitat per acabats de grau K10. S'utilitza en ferro fos, alumini i aliatges termorresistents. Aquesta qualitat funciona bé en aliatges amb base de cobalt i en materials sintètics, i també es pot utilitzar per acabats en aliatges termorresistents.

PM25

General purpose uncoated grade in the P30 range. This tough, economical grade is suitable for the machining of carbon steels, alloyed steels, tool steels and stainless steels.

PM25 provides toughness and resistance to deformation in roughing and semi-finishing operations.

Qualitat no recoberta de grau P30 per a usos generals. Aquesta qualitat econòmica i tenaç s'utilitza per el mecanitzat d'acers al carboni, acers aliats, acers refractaris i acers inoxidable. Ofereix tenacitat i resistència a la deformació en operacions de desbast i semiacabat.

Grinding / Esmolat

In order to obtain a satisfactory result, it is necessary to have a steady grinding table or holder that can be set to the required angle by means of a graduated scale and by non-vibrating small spindles.

Rough grinding is normally carried out using a silicon carbide grinding wheel. The finish grind or lapping must always be made using a diamond wheel.

Longer life of the cutting edge and less breakage justify the increased cost of correct grinding.

The grinding wheel must be kept clean to ensure that cutting capacity is maintained.

Whenever possible, always grind perpendicular to the cutting edge.

Per obtenir un resultat satisfactori, és necessari tenir una taula d'esmolat ferma o un suport amb petits eixos no vibrants que es pugui regular a l'angle necessari mitjançant una escala graduada.

L'esmolat de desbast es realitza normalment utilitzant una mola de carbur de silici. L'esmolat d'acabat o lapidatge s'ha de fer sempre utilitzant una mola de diamant.

Una duració més llarga de l'aresta de tall i menys trencaments justifiquen l'increment de cost d'un rectificat correcte.

La mola s'ha de mantenir neta per assegurar que es manté la capacitat de tall.

Sempre que sigui possible, esmoleu perpendicularment a l'aresta de tall.

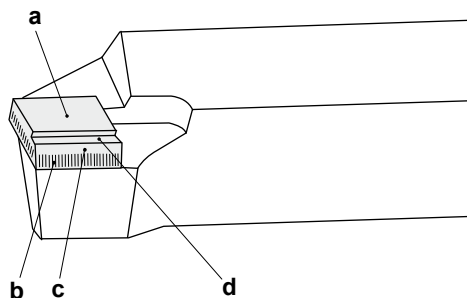

- a.- Top face / Cara superior
- b.- Secondary clearances / Incidència secundària
- c.- Lapped primary clearances / Incidència principal del lapidatge
- d.- Chipbreaker groove / Ranura del trencaferritges

Toolholders Portaeines

ISO 2 45°

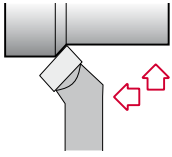

Page
Pàgina A272

ISO 6 90°

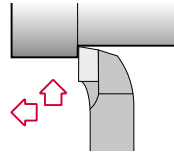

Page
Pàgina A272

ISO 7 90°

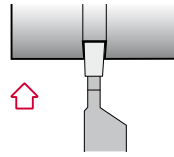

Page
Pàgina A273

ISO 351 80°

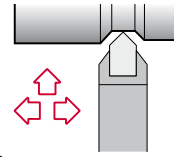

Page
Pàgina A273

UI 30 60°

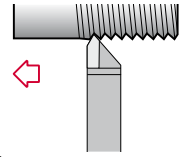

Page
Pàgina A274

Boring bars Barres de mandrinar

ISO 9 90°

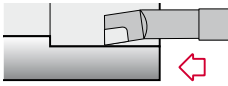

Page
Pàgina A275

UI 40 60°

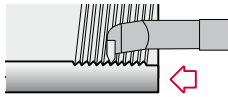

Page
Pàgina A275

UI 50 90°

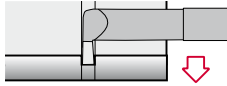

Page
Pàgina A276

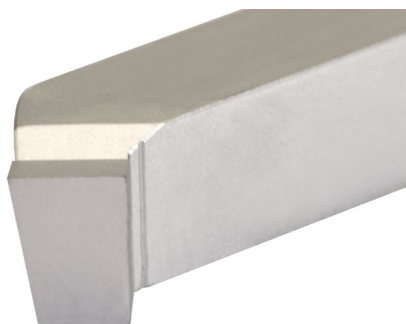

Characteristics:
Brazed toolholder.
DIN 4972

Característiques:
Eina soldada exterior.

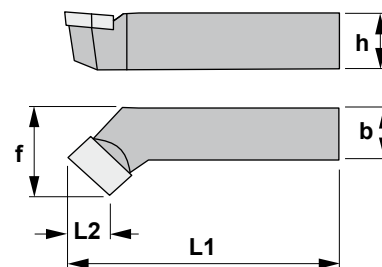
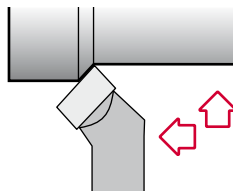

ISO 2 45°

| Reference Referència | h | b | L1 | L2 | f | Insert size Mida plaqueta | | KM15 | PM25 |
|-------------------------|----|----|-----|----|----|------------------------------|-------|----------------------------------|----------------------------------|
| ISO2 1010 R | 10 | 10 | 90 | 8 | 14 | C8 | 0,070 | <input type="radio"/> | <input type="radio"/> |
| ISO2 1010 L | 10 | 10 | 90 | 8 | 14 | C8 | 0,070 | <input type="radio"/> | <input type="radio"/> |
| ISO2 1212 R | 12 | 12 | 100 | 10 | 17 | ABC10 | 0,100 | <input type="radio"/> | <input checked="" type="radio"/> |
| ISO2 1212 L | 12 | 12 | 100 | 10 | 17 | ABC10 | 0,100 | <input type="radio"/> | <input checked="" type="radio"/> |
| ISO2 1616 R | 16 | 16 | 110 | 12 | 22 | ABC12 | 0,200 | <input checked="" type="radio"/> | <input checked="" type="radio"/> |
| ISO2 1616 L | 16 | 16 | 110 | 12 | 22 | ABC12 | 0,200 | <input checked="" type="radio"/> | <input checked="" type="radio"/> |
| ISO2 2020 R | 20 | 20 | 125 | 16 | 28 | ABC16 | 0,400 | <input checked="" type="radio"/> | <input checked="" type="radio"/> |
| ISO2 2020 L | 20 | 20 | 125 | 16 | 28 | ABC16 | 0,400 | <input checked="" type="radio"/> | <input checked="" type="radio"/> |
| ISO2 2525 R | 25 | 25 | 140 | 20 | 35 | ABC20 | 0,650 | <input checked="" type="radio"/> | <input checked="" type="radio"/> |
| ISO2 2525 L | 25 | 25 | 140 | 20 | 35 | ABC20 | 0,650 | <input checked="" type="radio"/> | <input checked="" type="radio"/> |

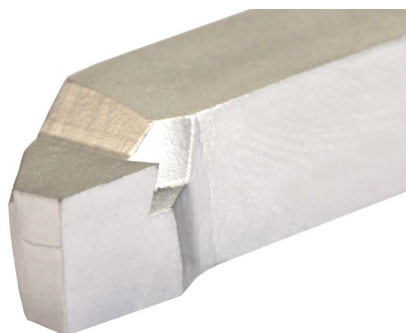

Characteristics:
Brazed toolholder.
DIN 4980

Característiques:
Eina soldada exterior.

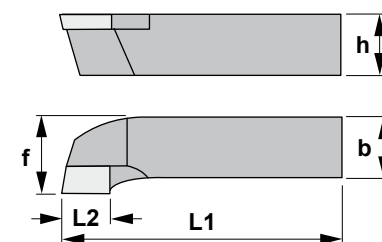
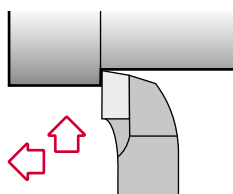

i AVAILABILITY / DISPONIBILITAT
 Standard item / Article estàndard
 Check availability / Consulti disponibilitat

ISO 6 90°

| Reference Referència | h | b | L1 | L2 | f | Insert size Mida plaqueta | | KM15 | PM25 |
|-------------------------|----|----|-----|----|----|------------------------------|-------|----------------------------------|----------------------------------|
| ISO6 1010 R | 10 | 10 | 90 | 8 | 14 | C8 | 0,070 | <input type="radio"/> | <input type="radio"/> |
| ISO6 1010 L | 10 | 10 | 90 | 8 | 14 | C8 | 0,070 | <input type="radio"/> | <input type="radio"/> |
| ISO6 1212 R | 12 | 12 | 100 | 10 | 17 | ABC10 | 0,100 | <input type="radio"/> | <input checked="" type="radio"/> |
| ISO6 1212 L | 12 | 12 | 100 | 10 | 17 | ABC10 | 0,100 | <input type="radio"/> | <input checked="" type="radio"/> |
| ISO6 1616 R | 16 | 16 | 110 | 12 | 22 | ABC12 | 0,200 | <input checked="" type="radio"/> | <input checked="" type="radio"/> |
| ISO6 1616 L | 16 | 16 | 110 | 12 | 22 | ABC12 | 0,200 | <input checked="" type="radio"/> | <input checked="" type="radio"/> |
| ISO6 2020 R | 20 | 20 | 125 | 16 | 28 | ABC16 | 0,400 | <input checked="" type="radio"/> | <input checked="" type="radio"/> |
| ISO6 2020 L | 20 | 20 | 125 | 16 | 28 | ABC16 | 0,400 | <input checked="" type="radio"/> | <input checked="" type="radio"/> |
| ISO6 2525 R | 25 | 25 | 140 | 20 | 35 | ABC20 | 0,650 | <input checked="" type="radio"/> | <input checked="" type="radio"/> |
| ISO6 2525 L | 25 | 25 | 140 | 20 | 35 | ABC20 | 0,650 | <input checked="" type="radio"/> | <input checked="" type="radio"/> |



Characteristics:
Brazed toolholder.
DIN 4981

Característiques:
Eina soldada exterior.

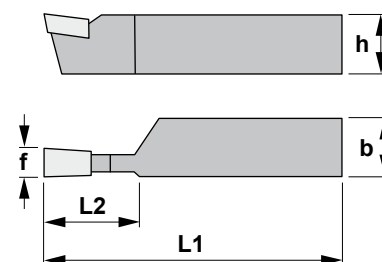
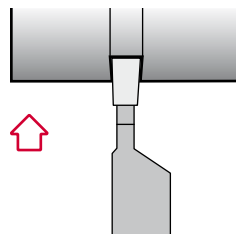

ISO 7 90°

| Reference Referència | h | b | L1 | L2 | f | Insert size Mida plaqueta | ⚖️ | KM15 | PM25 |
|-------------------------|----|----|-----|----|---|------------------------------|-------|------|------|
| ISO7 1208 R | 12 | 08 | 100 | 12 | 3 | D3 | 0,070 | ○ | ● |
| ISO7 1208 L | 12 | 08 | 100 | 12 | 3 | D3 | 0,070 | ○ | ● |
| ISO7 1610 R | 16 | 10 | 110 | 14 | 4 | D4 | 0,150 | ● | ● |
| ISO7 1610 L | 16 | 10 | 110 | 14 | 4 | D4 | 0,150 | ● | ● |
| ISO7 2012 R | 20 | 12 | 125 | 16 | 5 | D5 | 0,200 | ● | ● |
| ISO7 2012 L | 20 | 12 | 125 | 16 | 5 | D5 | 0,200 | ● | ● |
| ISO7 2516 R | 25 | 16 | 140 | 20 | 6 | D6 | 0,400 | ● | ● |
| ISO7 2516 L | 25 | 16 | 140 | 20 | 6 | D6 | 0,400 | ● | ● |
| ISO7 3220 R | 32 | 20 | 170 | 25 | 8 | D8 | 0,750 | ● | ● |
| ISO7 3220 L | 32 | 20 | 170 | 25 | 8 | D8 | 0,750 | ● | ● |

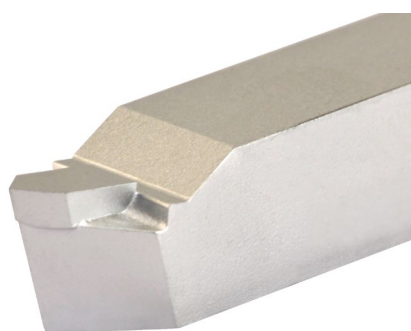

Characteristics:
Brazed toolholder.
DIN 4975

Característiques:
Eina soldada exterior.

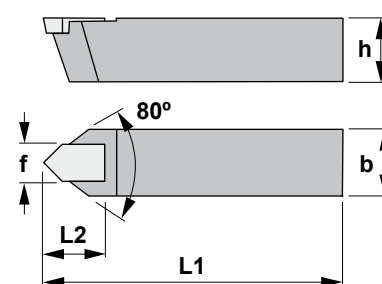
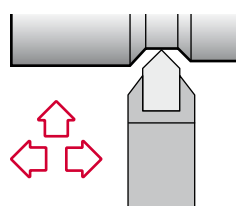

ISO 351 80°

| Reference Referència | h | b | L1 | L2 | f | Insert size Mida plaqueta | ⚖️ | KM15 | PM25 |
|-------------------------|----|----|-----|----|----|------------------------------|-------|------|------|
| ISO351 1212 N | 12 | 12 | 100 | 10 | 5 | E5 | 0,100 | ○ | ○ |
| ISO351 1616 N | 16 | 16 | 110 | 12 | 6 | E6 | 0,200 | ○ | ○ |
| ISO351 2020 N | 20 | 20 | 125 | 16 | 8 | E8 | 0,400 | ○ | ○ |
| ISO351 2525 N | 25 | 25 | 140 | 18 | 10 | E10 | 0,650 | ○ | ○ |

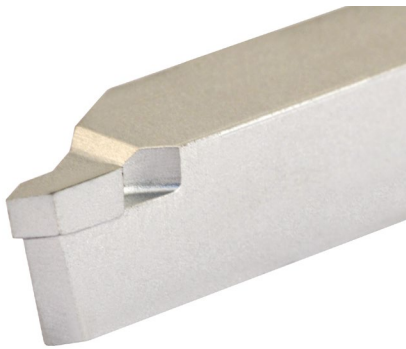

Characteristics:
Brazed toolholder.
ISO 352

Característiques:
Eina soldada exterior.

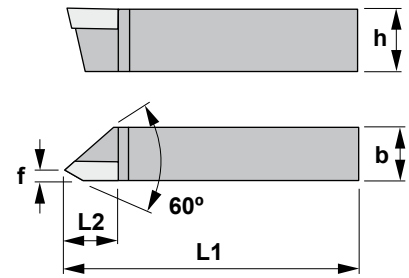
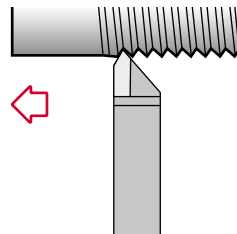

UI 30 60°

| Reference Referència | h | b | L1 | L2 | f | Insert size Mida plaqueta |  | KM15 | PM25 |
|-------------------------|----|----|-----|----|-----|------------------------------|---|------|------|
| UI 30 60° 1212 R | 12 | 12 | 100 | 12 | 1,8 | E5 | 0,100 | ● | ● |
| UI 30 60° 1616 R | 16 | 16 | 110 | 14 | 2,0 | E6 | 0,200 | ● | ● |
| UI 30 60° 2020 R | 20 | 20 | 125 | 16 | 2,5 | E8 | 0,350 | ● | ● |
| UI 30 60° 2525 R | 25 | 25 | 140 | 18 | 3,0 | E10 | 0,600 | ● | ● |

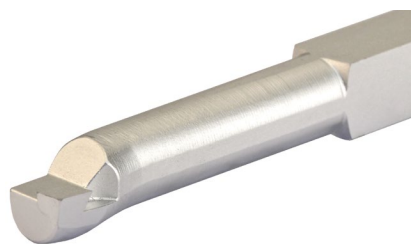

Characteristics:
Brazed boring bar.
UNI 4111

Característiques:
Eina soldada interior.

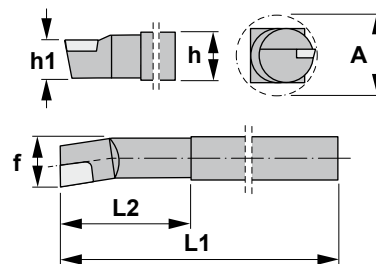
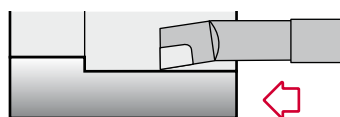

ISO 9 90°

| Reference Referència | h=b | h1 | L | b2 | L2 | f | A | Insert size Mida plaqueta | | KM15 | PM25 |
|-------------------------|-----|------|-----|------|-----|----|----|------------------------------|-------|------|------|
| ISO9 0808 R | 8 | 6,4 | 125 | 3,1 | 40 | 11 | 14 | C7 | 0,060 | ● | ● |
| ISO9 1010 R | 10 | 8,0 | 150 | 4,0 | 50 | 14 | 18 | C7 | 0,100 | ● | ● |
| ISO9 1212 R | 12 | 9,6 | 180 | 5,1 | 63 | 17 | 21 | C8 | 0,250 | ● | ● |
| ISO9 1616 R | 16 | 12,8 | 210 | 6,2 | 80 | 22 | 27 | ABC 10 | 0,400 | ● | ● |
| ISO9 2020 R | 20 | 16,0 | 250 | 8,3 | 100 | 28 | 34 | ABC 12 | 0,700 | ● | ● |
| ISO9 2525 R | 25 | 20,0 | 300 | 10,0 | 125 | 35 | 43 | ABC 16 | 1,300 | ● | ● |
| ISO9 3232 R | 32 | 25,6 | 355 | 12,0 | 160 | 44 | 52 | ABC 20 | 2,500 | ● | ● |

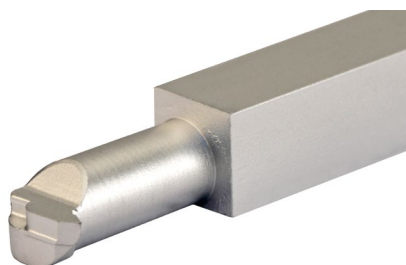

Characteristics:
Brazed boring bar.
ISO 353

Característiques:
Eina soldada interior.

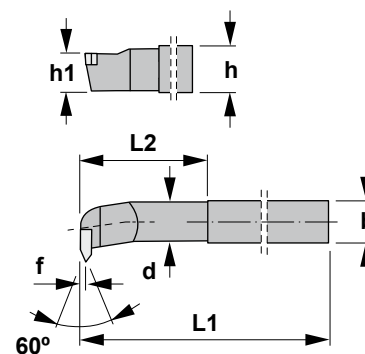
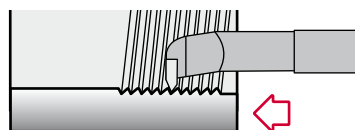

i AVAILABILITY / DISPONIBILITAT
● Standard item / Article estàndard
○ Check availability / Consulti disponibilitat

UI 40 60°

| Reference Referència | d | h=b | L | L2 | f | Insert size Mida plaqueta | | KM15 | PM25 |
|-------------------------|----|-----|-----|----|-----|------------------------------|-------|------|------|
| UI 40 60° 1010 R | 10 | 10 | 100 | 26 | 1,8 | E4 | 0,070 | ● | ● |
| UI 40 60° 1212 R | 12 | 12 | 110 | 26 | 1,8 | E4 | 0,200 | ● | ● |
| UI 40 60° 1616 R | 16 | 16 | 140 | 33 | 2,0 | E5 | 0,250 | ● | ● |
| UI 40 60° 2020 R | 20 | 20 | 160 | 41 | 2,0 | E6 | 0,450 | ● | ● |
| UI 40 60° 2525 R | 25 | 25 | 180 | 49 | 2,5 | E8 | 0,750 | ● | ● |

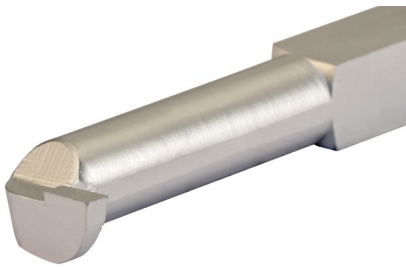

Characteristics:
Brazed boring bar.
ISO 354

Característiques:
Eina soldada interior.

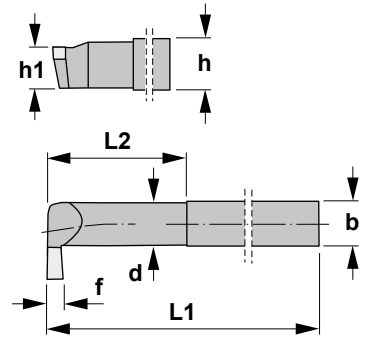
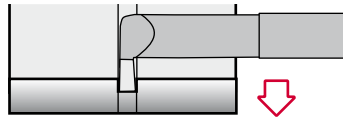

UI 50 90°

| Reference Referència | d | h=b | L | L2 | f | Insert size Mida plaqueta |  /Kg | KM15 | PM25 |
|-------------------------|----|-----|-----|-----|---|------------------------------|---|------|------|
| UI 50 90° 1010 R | 10 | 10 | 140 | 52 | 3 | D3 | 0,100 | ● | ● |
| UI 50 90° 1212 R | 12 | 12 | 160 | 56 | 4 | D4 | 0,200 | ● | ● |
| UI 50 90° 1616 R | 16 | 16 | 180 | 63 | 5 | D5 | 0,350 | ● | ● |
| UI 50 90° 2020 R | 20 | 20 | 210 | 80 | 6 | D6 | 0,700 | ● | ● |
| UI 50 90° 2525 R | 25 | 25 | 250 | 100 | 8 | D8 | 1,250 | ● | ● |